

Two Channel Optical Interrupters May be Used for Determining Direction of Rotation, Speed, and the Relative Location of a Rotating Shaft

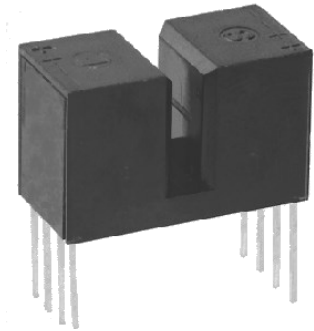

Application Bulletin 203



Optek has two types of dual channel optical interrupters available. The OPB822 family has two side-by-side channels on 0.212" centers and the OPB826 family has two vertical channels on 0.150" centers. These standard parts may be used for determining direction of rotation, speed, and relative location of a rotating shaft. This bulletin will discuss some of the design aspects of two channel encoding along with circuit concepts and unit performance.

General Discussion

Rotational direction of a shaft can be readily determined by utilizing the two channels of an optical interrupter, an encoder disc with a number of openings around the circumference, and some simple electronics. The speed and relative shaft location information is available as a by-product and requires some additional electronics.

Figure 1 is a pictorial definition of terms used in this bulletin and should be referred to for clarification. A period is defined as 360 electrical degrees or the mechanical width of one opening plus one closure at the central point of the slot near the circumference of the encoder disc. When using a vertical, dual-channel unit, the outer row of periods are normally offset by 90 electrical degrees, or 1/4 period, from the inner row of periods. This will cause one channel to turn on approximately 90 electrical degrees ahead of the other as a function of rotation. In shaft encoding terminology, quadrature is the term defining determination of rotational direction by the phase relationship between the outputs of the two channels. System design normally uses 90° for this phase shift.

Speed can be determined by accumulating the number of signal pulses for a fixed period of time, dividing by the number of periods per revolution thus obtaining the revolutions for this time period. Relative location is determined by dividing 360 by the number of periods around the circumference. A pulse is generated for each of these rotational segments. Counters may be used to relate a certain number the method of obtaining the three pieces of information (rotation direction, speed, and relative location) rather than what is done with the information.

FIGURE 1
Pictorial Definition of Terms

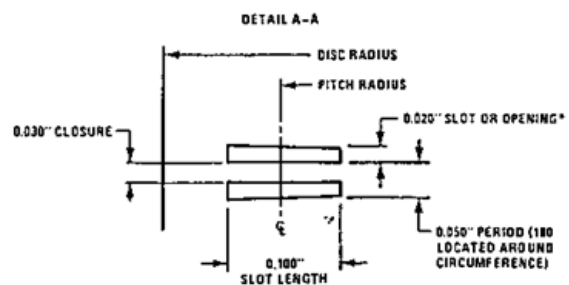
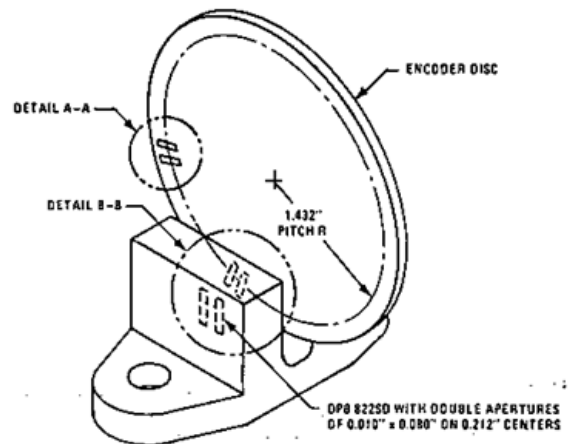

* The sides of the slots lie on the extension of the two radii that are 1.432" long and 0.020" apart at the chord that defines the width of the center of the slot. The contained \angle at that point is 0.8°.

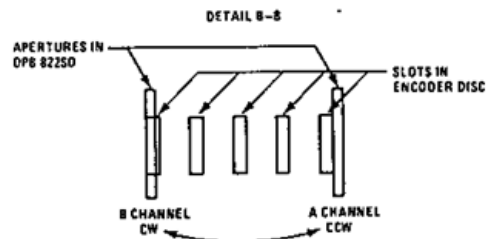

General Note

TT Electronics reserves the right to make changes in product specification without notice or liability. All information is subject to TT Electronics' own data and is considered accurate at time of going to print.

TT Electronics | Optek Technology
1645 Wallace Drive, Suite 130, Carrollton, TX, USA 75006 | Ph: +1 972-323-2300
www.ttelectronics.com | sensors@ttelectronics.com

Performance Characteristics

The OPB822SD is used as the demonstration interrupter to describe method and operation. Apertures (0.010" x 0.080") are mounted in front of both sensors and LEDs. The 0.010" dimension is perpendicular to the rotational vector of the encoder disc at the slot between the sensor and LED. A system is desired with 2° mechanical resolution of rotational movement, thus 360°/2 or 180 cycles or periods around the circumference. Each cycle or period corresponds to an opening and a closure in the encoder disc passing a sensor and LED combination.

An off-multiple of periods between the center line of the sensor apertures (0.212") is required for the 90° phase shift. This off-multiple can be 1/4, 3/4, 1-1/4, 1-3/4, 2-1/4, 2-3/4 etc. periods. For example, a period of 0.050" will yield 4-1/4 cycles or periods in the 0.212" distance between these apertures. The radius of the encoder disc is determined to be 1.432". (0.050" period x 180 periods per revolution x 1/2 π = radius). The opening in the disc should not be less than 0.010" as this would decrease the guaranteed output signal. A good rule for designing encoders is to keep the ratio of the opening to the closure at 2/3's. The disc can now be specified as:

- Pitch radius—1.43" (from center of wheel to CL of slots and apertures)
- Slot length—0.100" (0.020" tolerance above 0.080" aperture)
- Disc radius—1.562" (0.025" tolerance between disc and bottom of slot)
- Openings—0.020" on chord at 1.432" radius (180 required)
- Closure—0.030" on chord at 1.432" radius (180 required)
- Disc material and thickness—polycarbonate plastic, 0.060" thick

Crosstalk will not occur due to the narrow apertures (0.010") on both sensor and LED. This disc was then paired with the circuit shown in Figure 2.

$$\frac{0.212}{\text{off-multiple}} \times \text{mechanical resolution (pulses/revolution)} \times 1/2 \pi = \text{pitch radius.}$$

As shown in Figure 2, channel "B" provides the "D" input and channel "A" provides the "clock" input to the SN7414. (The SN7414 converts the relatively slow transitions from the mechanical motion to TTL compatible rise and fall times.) Since channel "A" clocks the latch at its positive transition, the state of channel "B" at "D" determines the state of the latch. If the "O" output of the latch is high (1 state) then the "D" input was high when channel "A" turned "ON". Thus channel "B" turned "ON" prior to channel "A". This implies counterclockwise direction of rotation.

FIGURE 2 - Schematic for Determination of Rotation Direction, Relative Position and Speed

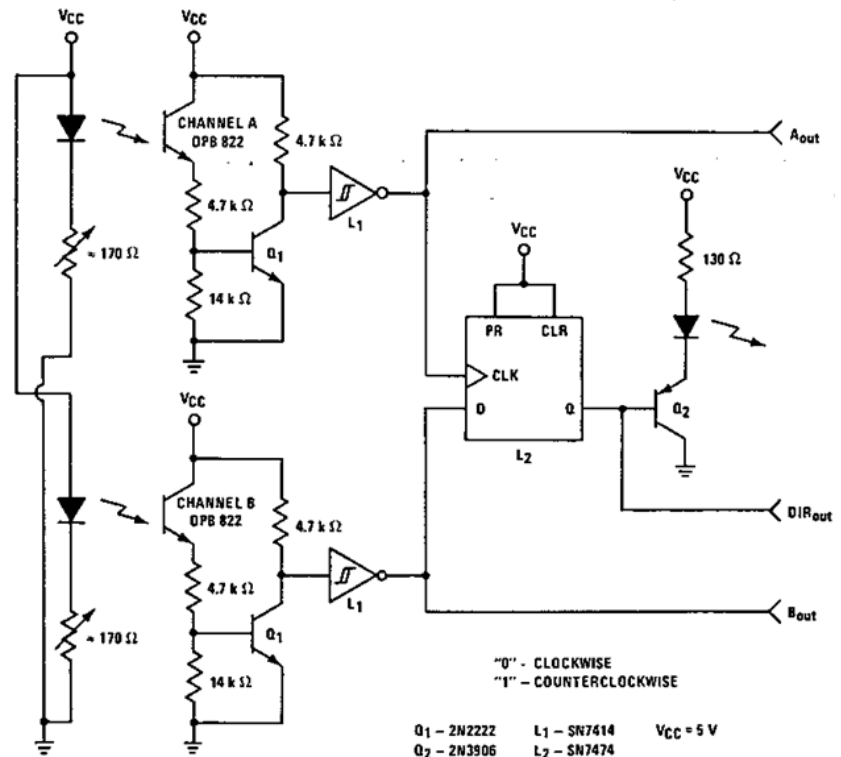

General Note

TT Electronics reserves the right to make changes in product specification without notice or liability. All information is subject to TT Electronics' own data and is considered accurate at time of going to print.

TT Electronics | Optek Technology
 1645 Wallace Drive, Suite 130, Carrollton, TX, USA 75006 | Ph: +1 972-323-2300
 www.ttelectronics.com | sensors@ttelectronics.com

Two Channel Optical Interrupters

Application Bulletin 203



For clockwise rotation, channel "A" turns on prior to channel "B" and the "O" output of the latch will be low (0 state). The pulses at A out or B out may be used for speed and/or relative location. Speed may be determined by counting the output pulses for a given time period and the dividing the total count by 180 (pulses per revolution). Relative event location may be controlled within approximate 2° accuracy (360°/180) by specifying the number of pulses between related events. For example, 45 pulses would correspond to 1/4 rotation or 90 mechanical rotational degrees.

The photographs shown in Figure 3 demonstrate the "0" and "1" level for clockwise and counterclockwise rotation.

The left photograph shows a "0" level denoting clockwise rotation. The right photograph shows the opposite. Additional circuitry may be added using the time base pulses already present. If a third interrupter channel were added that could relate back to a fixed location of the shaft, then the relative location could be changed to true location. This might become the left margin control, right margin control and/or index for next line control. All of these functions could be performed quite easily. The same technique may be used in linear motion where the encoder disc is replaced by a comb with a series of openings and closures. The direction of movement, speed, and the relative location of the comb could be used as discussed before by molding the comb with the opening 0.020" wide by 0.100" high every 0.050" length along the comb.

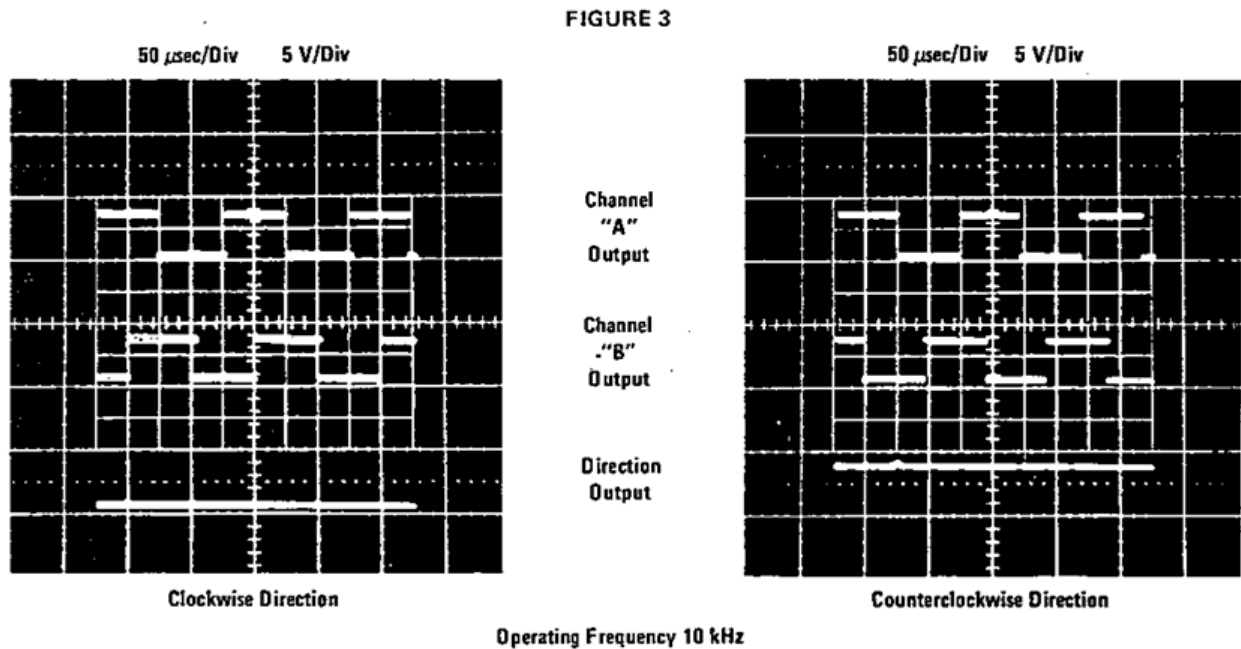

Conclusion

In summary, this is a very versatile technique for relating electrical signals to linear or rotational motion, speed and either relative or true location of that motion.

Richard Dahlberg

William Nunley