

## UL RECOGNISED FUSIBLE RESISTORS EMC AND ULW SERIES - Application Note

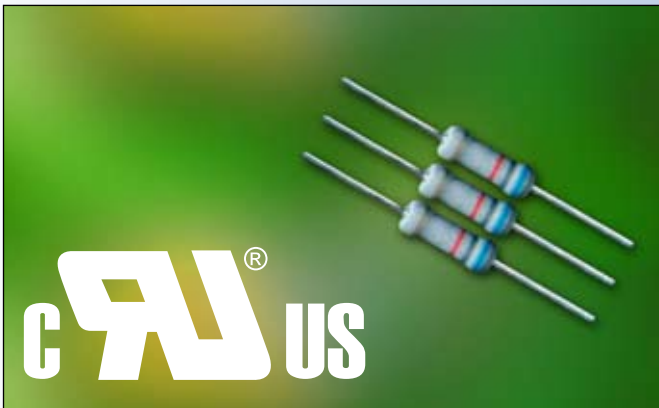

### Background

Designers of power supplies and battery chargers for consumer products are faced with many conflicting requirements. One of the goals is to minimise manufacturing cost whilst maintaining standards of product safety. EMC and ULW products provide a mains (line) input solution, which both reduces component count and provides a UL recognised part.

Another conflict related to the input resistor is that of pulse performance versus fusing performance.

The chosen solution must be sufficiently robust to withstand inrush currents and line transients, and yet open the circuit safely and rapidly in a fault condition. This calls for products with fully specified surge and fuse characteristics, such as EMC and ULW.

This application note aims to simplify the processes of value selection and design verification, and should be read in conjunction with the full product datasheet.



- **Fusible resistor replaces resistor + fuse combination in mains (line) input applications**
- **UL recognised component simplifies UL approval of equipment**
- **Exceptional pulse performance**
- **Compact flameproof body with several leadforming options**
- **Choice of film technology (EMC) or wirewound (ULW)**

## UL RECOGNISED FUSIBLE RESISTORS EMC AND ULW SERIES - Application Note

### Power Supply Application

EMC and ULW are aimed chiefly at mains input protection for small power supplies and battery chargers. Here it performs three circuit protection functions:

1. Providing protection against supply line voltage transients, often in conjunction with a shunt element such as a Varistor or Transient Voltage Suppressor (TVS). This enables the designer to achieve the required level of immunity to conducted lightning induced surges.

2. Restricting the peak inrush current at switch-on to levels suitable for the rectifier bridge and consistent with good EMC design.

3. Preventing fire by fusing safely under fault conditions such as rectifier or capacitor breakdown.

Figure 1 shows a typical application in which the input resistor and mains fuse may be replaced by a single component.

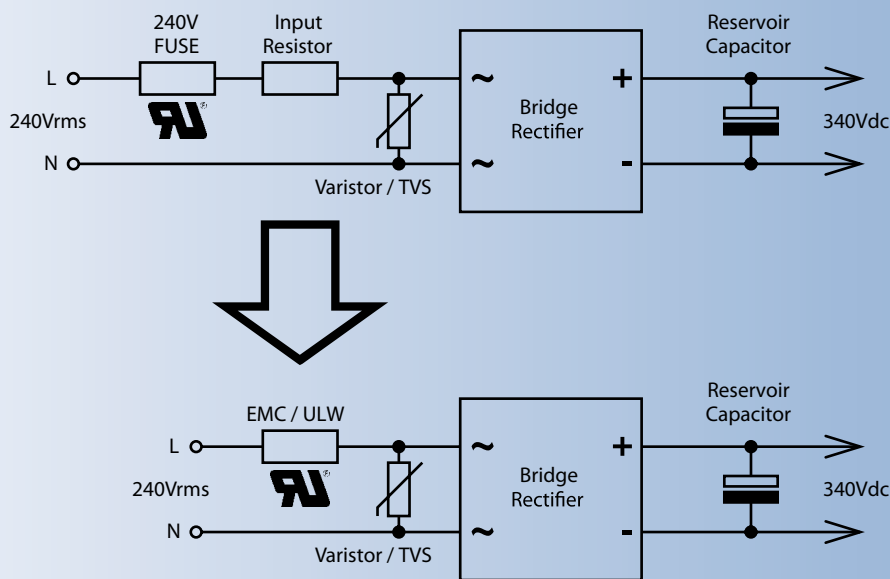

Figure 1

The three protection functions are considered in detail below.

### Lightning Strike Pulse Performance

This type of supply line disturbance arises when a lightning strike occurs close to power lines and a transient high voltage is induced in the power system. A common standard for simulating the resulting surge is IEC61000-4-5, which describes a 1.2/50µs pulse, is illustrated in Figure 2. The maximum permissible peak voltage across a resistor is limited by pulse energy considerations, and so is dependent on resistance value. The performance characteristics are shown in Figure 3.

When calculating the peak voltage across the resistor, allowance should be made for varistor clamping voltage and, for low resistance values, the circuit and source impedance. The first of these is defined on the varistor / TVS datasheet, and should be subtracted from the peak voltage appearing at the supply line terminals. The second is the combined resistance of the supply source and, if significant, the rest of the circuit. The standard value usually used for supply source impedance is 2 ohms.

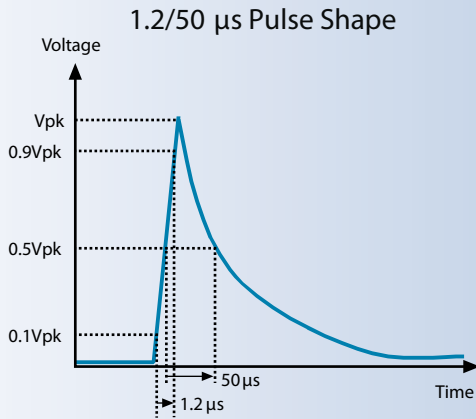

Figure 2

### Example 1

What maximum 1.2/50µs peak voltage can be applied to an input circuit comprising ULW2-47R and a 250Vrms Metal Oxide Varistor (MOV) with a clamping voltage of 700V at 30A?

Source and circuit impedances are negligible, and the maximum peak voltage for ULW2-47R is 1.2kV. The peak current is  $1200V / 47 = 26A$ , so a reasonable estimate of the MOV voltage drop is 600V, giving a total of 1.8kV.

### Example 2

What maximum 1.2/50µs peak voltage can be applied to an input circuit comprising EMC2-4R7 and a 250Vrms Metal Oxide Varistor (MOV) with a clamping voltage of 800V at 50A?

Source impedance is  $2 \Omega$  and circuit impedance is  $300m\Omega$ .

The total resistance is  $4.7 \Omega + 2 \Omega + 0.3 \Omega = 7 \Omega$ , and the maximum permitted peak voltage across EMC2-4R7 is 160V. This gives a peak current of  $160V / 4.7\Omega = 34A$ . The peak voltage across the total resistance is  $7\Omega / 4.7 \Omega \times 160V = 240V$ , and the MOV will drop about 750V, giving a total peak voltage of just under 1kV.

## Inrush Pulse Performance

The graphs in Figure 4 may be used to determine the pulse performance of EMC2 in a mains (line) input application. The upper left graph shows the worst-case peak power developed in the resistor at switch-on for 115 / 240Vrms supply voltages, which is  $2 \times V^2 / R$ , where V is RMS voltage, and R is resistance value. This is the maximum inrush, seen when switching occurs at peak voltage in the AC cycle; for inrush time constants greater than 10ms, the peak power will be less - closer to  $V^2 / R$  for a full bridge circuit. It is conservative to assume the inrush resistor to be the only resistance in the circuit, but for values below 10R, source and circuit resistances may reduce the peak power seen by the resistor.

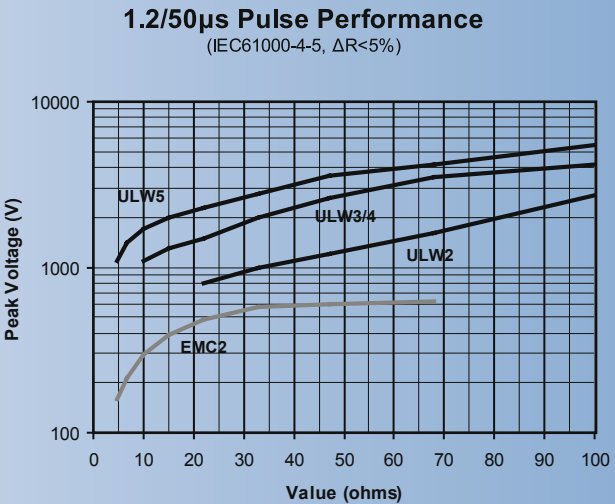

Figure 3

The upper right graph shows the peak power limit for EMC2 as a function of pulse width. The data here is for single rectangular pulses. The actual pulse shape in this application has an exponential decay, but this may be converted to an equivalent rectangular pulse of equal energy, the width of which is half the time constant, that is  $RC / 2$ . The lower right graph simply relates resistance value to equivalent rectangular pulse width for different values of reservoir capacitor.

For ULW, Figure 5 shows the energy limit as a function of ohmic value. As this is wirewound rather than film technology, the inrush duration has no effect on the energy capacity.

## UL RECOGNISED FUSIBLE RESISTORS EMC AND ULW SERIES - Application Note

### Example 1

A reservoir capacitor of 100 $\mu$ F is to be used in a 240V mains input circuit. The continuous current drawn from the mains supply will be 100mA. Select a value of EMC2 that gives inrush protection and minimises the continuous power dissipation.

Starting from an arbitrary low value of 10R, use lower right graph to establish pulse width for 100 $\mu$ F (0.5ms). Take this to the upper right graph and read off peak power (3.7kW). Take this to the upper left graph for 240V resistance value (30). Take this back to the lower right graph and repeat this iterative process, which will converge to the required value of around 47R. Higher values could be used, but this keeps the power dissipation down to  $(0.1A)^2 \times 47 = 0.5W$ .

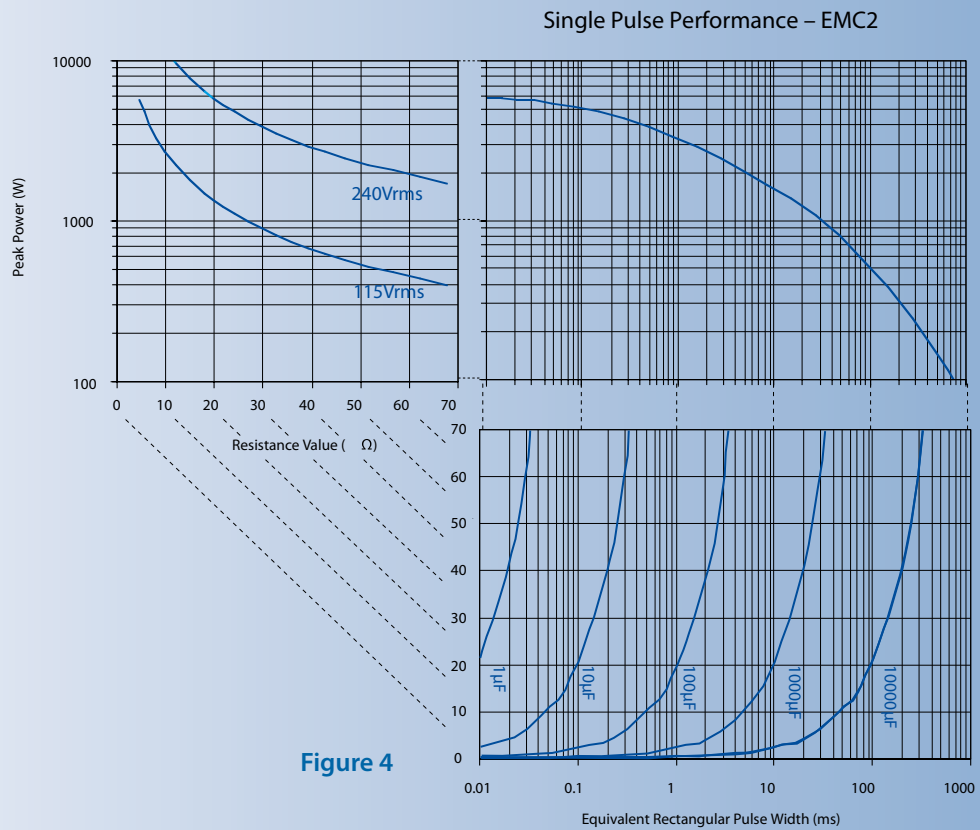

### Example 2

An inrush resistor of 33R is being used in a line input circuit where, after step down transformer and rectifier, a reservoir capacitor of 10,000 $\mu$ F  $\pm$ 20% is charged to 30V. What size of ULW is required for this?

The maximum capacitance is 12,000 $\mu$ F, and charging energy is given by  $E = \frac{1}{2} C.V^2$  which is 5.3J. From Figure 5, the smallest size which meets this energy capacity at 33R is ULW3.

### ULW Pulse Energy Limit

(single or low repetition rate,  $\Delta R < 5\%$ )

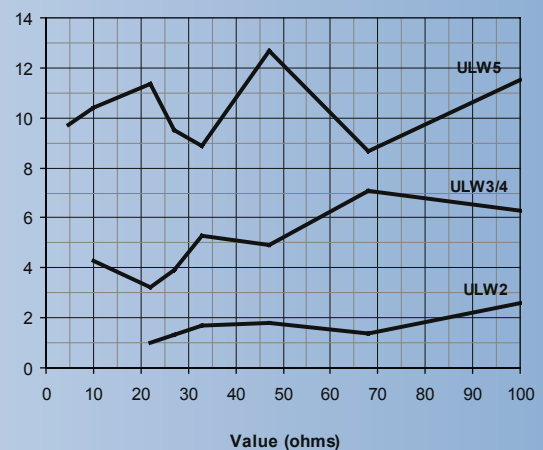

## UL RECOGNISED FUSIBLE RESISTORS EMC AND ULW SERIES - Application Note

### Fusing Performance

The maximum time for fusing operation can be derived from Figure 6. For fusible resistors, unlike fuses, fusing performance is given in terms of power rather than current. But for a given resistance value R, the current can be calculated from the power figure P by using  $P = I^2R$ .

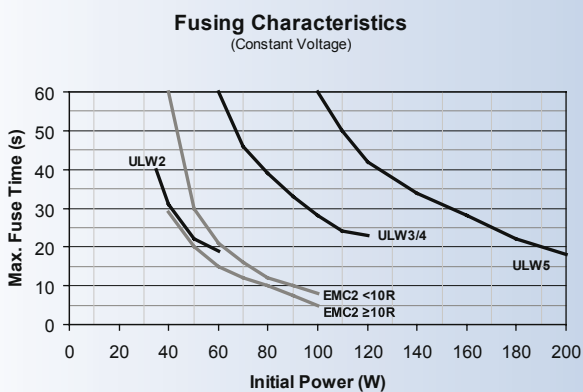

Figure 6

The data in Figure 6 relates to slow fusing in the region of the minimum fusing power. Typical fusing times are around 1/3 of the maximum figures. In a short circuit capacitor or rectifier failure, most of the supply voltage appears across the resistor, giving powers for EMC2 in excess of 200W for 115V and in excess of 850W for 240V. Under these conditions, the typical and maximum fusing times are as given in Table 1.

#### Example

What is the maximum fusing time for EMC2-22R with a fault current of 1.5Arms?

The initial power is  $(1.5A)^2 \times 22 = 50W$ , so the maximum fusing time is 20 seconds.

Table 1 mains Short Circuit fusing

Fuse Time (s)	115V		240V	
	Typ.	Max.	Typ.	Max.
4R7	0.1	0.3	0.03	0.1
68R	1	3	0.1	0.3

### UL1412 Recognition

EMC2 and ULW series are UL recognised (USA and Canada) fusible resistors with UL File Number E234469.

The main performance features that this ensures are as follows:

- Restricted maximum body temperature enables it to pass a gradual overload test without igniting "cheesecloth" at 13mm spacing
- Positive opening action ensures that the open circuit resistance after fusing exceeds 100 times original resistance

- Mains voltage fusing is without flame, incandescent fragments, or ignition of cotton material contacting the resistor body
- Manufacturing is regularly monitored by UL inspections
- Safety-critical aspects of electrical performance have been independently verified by UL Laboratories

### Mounting for Safe Operation

The following points should be noted when designing the PCB layout.

1. If the resistors are to dissipate full rated power, it is recommended that the terminations should not be soldered closer than 4mm from the body.
2. Due to operating temperature limits imposed by some PCB materials, derating may be necessary. An estimate of the temperature rise to be expected can be calculated using the thermal impedance figures given under Electrical Data in the Datasheet.

3. To protect against fire under all conditions of overload, a positive clearance of at least 13mm should be provided between the body of the resistor and any combustible materials.
4. These are flameproof resistors and so will not ignite. However, under limited overload leading to slow fusing times, the body temperature can become high enough to ignite adjacent materials. If this is a possible fault condition, it is vital that sufficient clearance from plastics and other components is provided. Also PCB standoff by leadforming should be used - see Leadforming Options.

## UL RECOGNISED FUSIBLE RESISTORS EMC AND ULW SERIES - Application Note

### Leadforming Options

The following examples show some of the formats in which these components may be supplied in order to permit minimised manufacturing cost and PCB standoffs for failsafe fusing. Many other leadforms are available and custom enquiries are welcome.

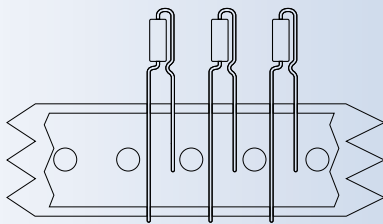

#### 1. Radial Taped (EMC2 only)

- Order product type with suffix 'R' (EMC2R)
- Reel packed
- For automatic radial insertion
- Minimises PCB footprint

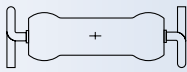
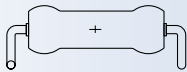

#### 2. Z-Form for SMD (all types)

- Order product type with suffix 'Z' (EMC2Z)
- Packed in plastic blister tape
- For vacuum pick and place and reflow soldering
- Through-hole power performance in SMD format

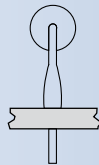
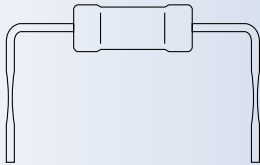

#### 3. Lancet for PCB standoff (all types)

- Order product type with suffix 'L' (EMC2L)
- Bulk Packed
- For manual insertion
- Standoff prevents PCB scorching

Note: Circuit diagrams are shown for example only.

**TT electronics: leading in fixed resistor technology.**

[www.ttelectronics.com](http://www.ttelectronics.com)

[www.bitechnologies.com](http://www.bitechnologies.com)

[www.irctt.com](http://www.irctt.com)

[www.welwyn-tt.com](http://www.welwyn-tt.com)

Europe: [sales@ttelectronicseurope.com](mailto:sales@ttelectronicseurope.com)

Asia: [sales@ttelectronicasia.com](mailto:sales@ttelectronicasia.com)

Americas: [sales@ttelectronics-na.com](mailto:sales@ttelectronics-na.com)



TT electronics companies

#### General Note

TT electronics reserves the right to make changes in product specification without notice or liability. All information is subject to TT electronics' own data and is considered accurate at time of going to print.